

Eurofit Loop Monitor Stand

Product Parts

- 1 - Left Shock-Cord Pole
- 2 - Right Shock-Cord Pole
- 3 - Front Bottom Pole
- 4 - Back Bottom Pole
- 5 - Left Adjustable Corners (x2)
- 6 - Bottom Braces (x3)
(2) - 20" & (1) - 15"
- 7 - Right Adjustable Corners (x2)
- 8 - LCD Mounting Poles (x2)
- 9 - Rear Pole

LCD Hardware

- 10 - LCD Bracket
- 11 - LCD Mounting Arms (x2)
- 12 - Tool Kit
 - Phillips Screws (x4)
 - Washers (x4)
 - Hex Wrench
- 13 - Graphic

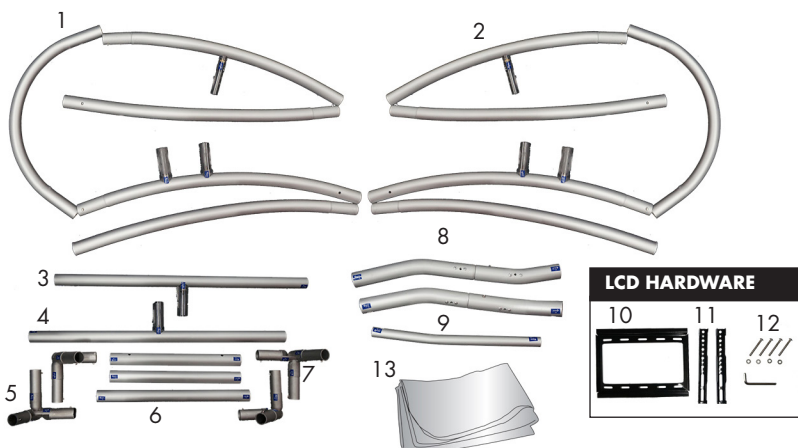

* You will need the use of a Phillips Screwdriver (Not Included)



Display Set-Up

Step 1

Remove everything from soft case and place on a clean flat surface. Verify you have all parts described above.

IMPORTANT INFORMATION

* During assembly, match the labels to each other on each connection point (Ex. T6 connects to T6).



Step 2

Assemble the bottom together by first, connecting the four Adjustable Corners (5/7) to the Front & Back Bottom Poles (3/4). Then connect the three Bottom Braces (6) to the Front Bottom Pole (3).

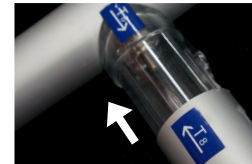
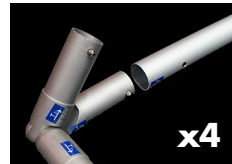

Step 3

Connect the Back Bottom Pole (4) to the three Bottom Braces (6).

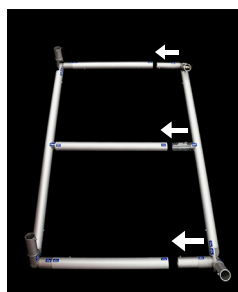

Step 4

Assemble the Left & Right Shock-Cord Poles (1/2), then connect to the four Adjustable Corners (5/7).

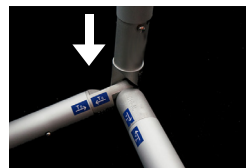

Step 5

Your display should now look like the image to the right.



Step 6

Connect the left ends of the two LCD Mounting Poles (8) to the port-holes on the Left Shock-Cord Pole (1). Do the same for the Rear Pole (9). Now, connect the Right Ends.

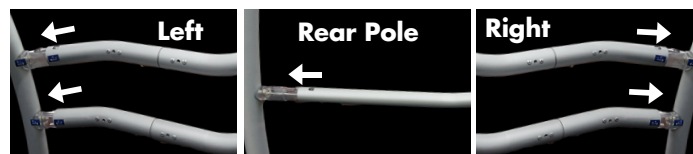

Display Set-Up Continued...

Step 7

Tighten all screws on each of the access holes around the display with the Hex-Wrench found in the Tool Kit (12).

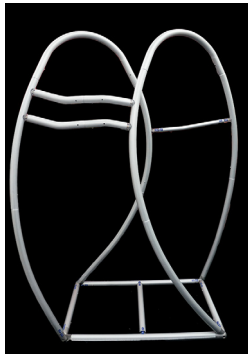

Graphic Set-Up

Step 8

Locate on the Graphic (13) where it says the word "Bottom", Lay this side face down on the floor. Set the hardware on the inside of the bottom panel.

Begin to pull the Graphic (13) upwards around the hardware.

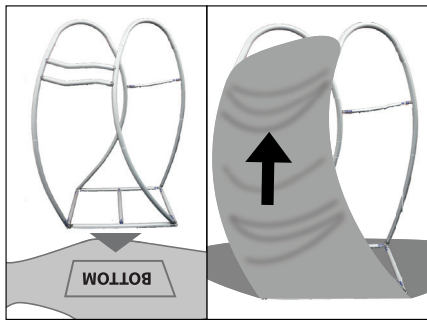

Step 9

Zip the Graphic (13) closed around the left side of the display.

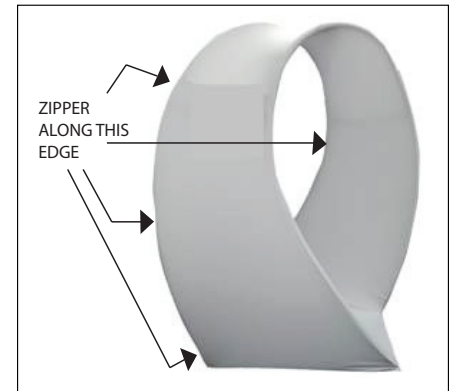

LCD Hardware Set-Up

Step 10

Using the four screws and washers from the Tool Kit (12) attach the LCD Bracket (10) to the display by lining up the holes on the LCD Bracket (10) to the holes on the LCD Mounting Poles (8).

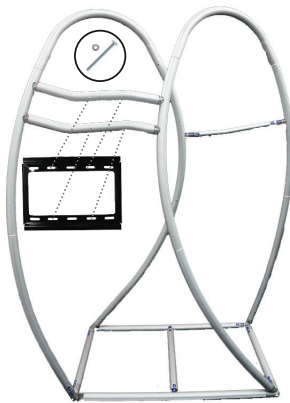

DISCLAIMER

Placing a TV that is too large or heavy for this stand could be hazardous and may cause the stand to be unstable. The TV/Monitor size limit is 32" measured diagonally, or a total weight of 25 lbs. The manufacturer is not liable for damage or injury caused by incorrect use of this television stand. Never allow children to climb or play on the stand.

Step 11

Attach the LCD Mounting Arms (11) to the back of your LCD Monitor. Screws are not included for this step as they come in different sizes based on your Brand of LCD Monitor.

Hang the LCD Mounting Arms (11) onto the LCD Bracket (10) as shown. Tighten the support screw on the back of each Mounting Arm (11).



* These Images shown are without an LCD Monitor Attached.

Storage & Care

Store in a cool dry location. Machine wash cold, gentle cycle. Air Dry Only