

TIMBERLINE LIGHTBOX

Set up Instructions

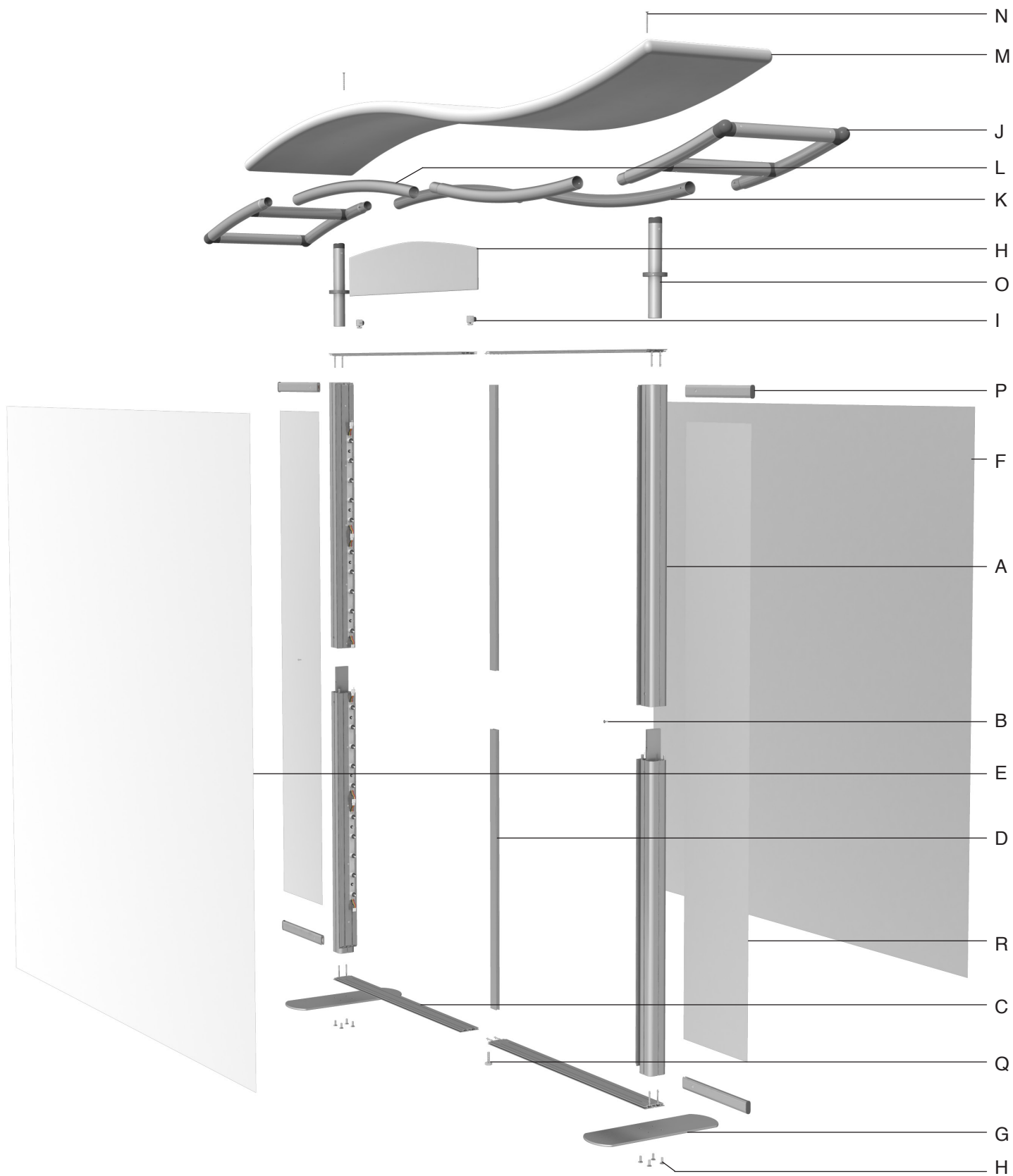

PARTS LIST



ASSEMBLY

- 1 On both vertical posts, locate the extruding portion and unscrew the bolt(s) located in the diagram below.

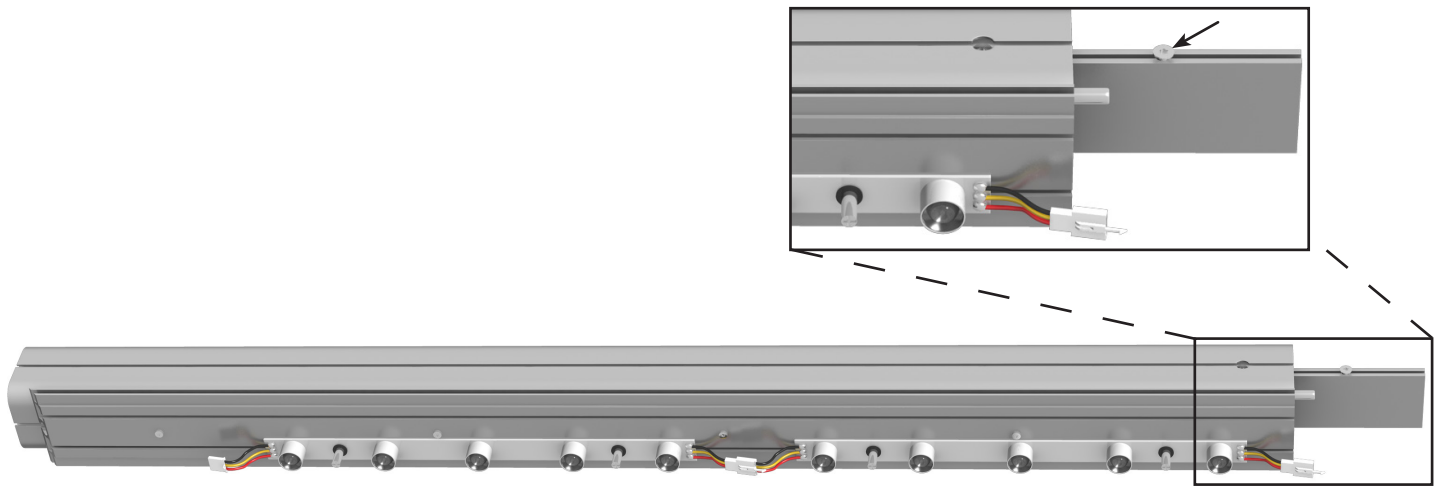

- 2 Locate the 2 left side and 2 right side vertical frame bars (A). Carefully attach the upper half of one side to the corresponding sides lower half by sliding the top half onto the bottom half, making sure that the extruding metal connector lines up correctly with the opening in the upper half. The upper half should slide into it securely. Do this for both the left and right side. Once complete, lay on floor and continue to build this frame while it lays flat on the ground.

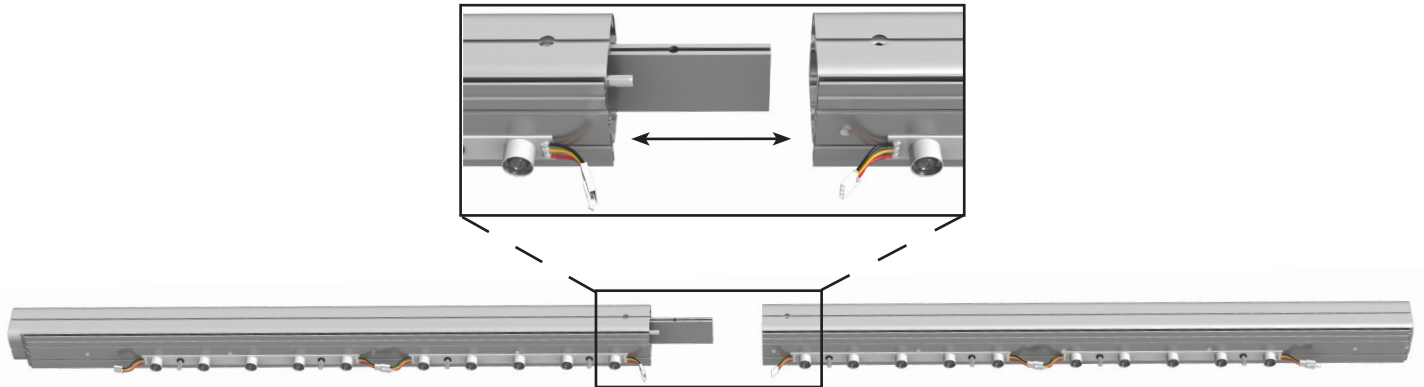

- 3 Screw in the two corresponding screws (B) for the upper and lower halves, securing the posts. Do this for both the left and right sides.

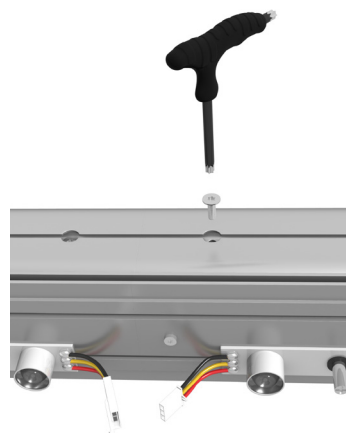

- 4** Connect the LED lights by connecting the two wire parts, as shown in the diagram.

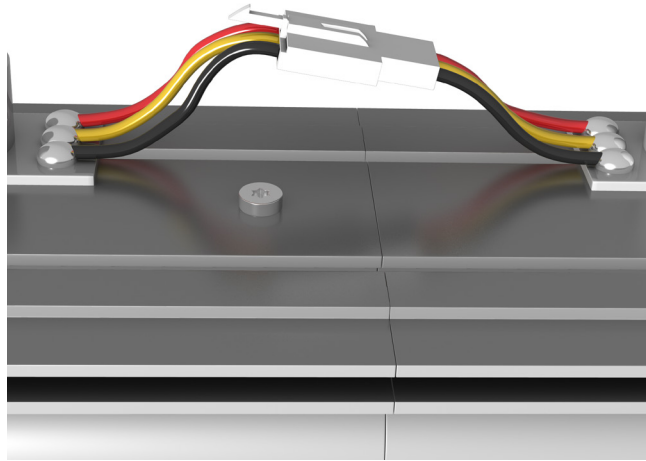

- 5** Locate the 2 top sections and 2 bottom sections of the frame (C). Connect by sliding the two sections together until secure. Use the supplied tool to secure.

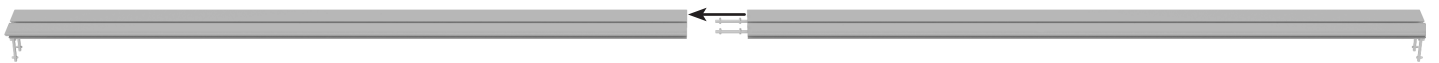

- 6** Slide both of the header supports into the middle opening of the top section of the frame, as seen in the diagram below. Tighten securely by twisting the supports clockwise.

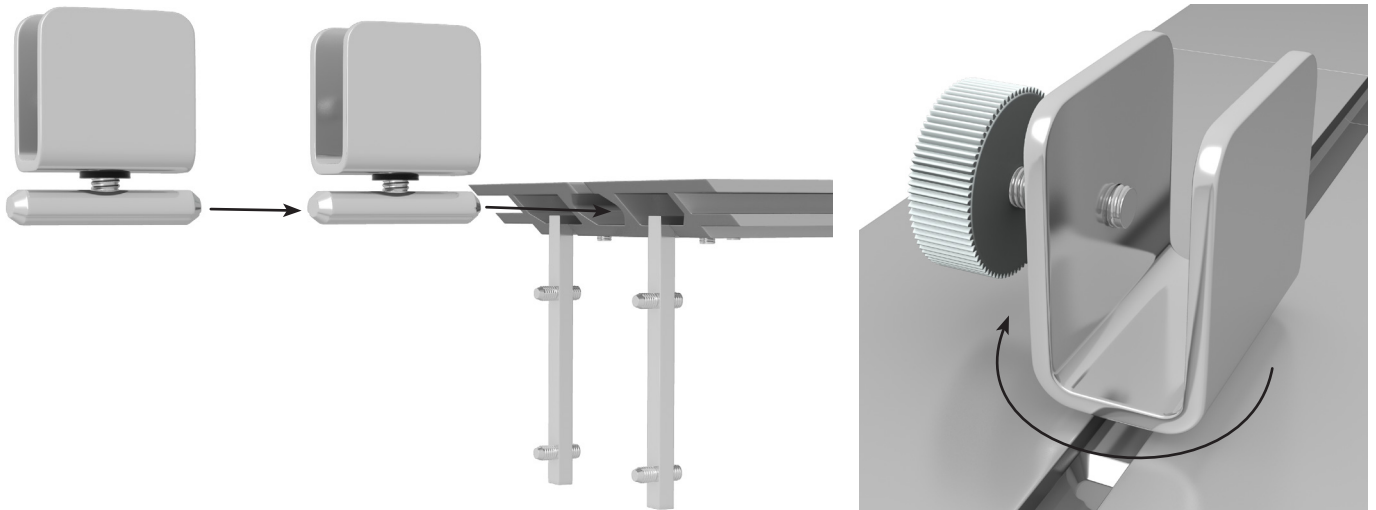

7

Connect the top and bottom sections (C) to the sides of the frame (A). Secure with the attached screws.



8

Attach the 2 sections of the middle post (D) and fasten using the supplied tool. Secure the middle post (D) to the middle portion of the frame using the supplied tool.

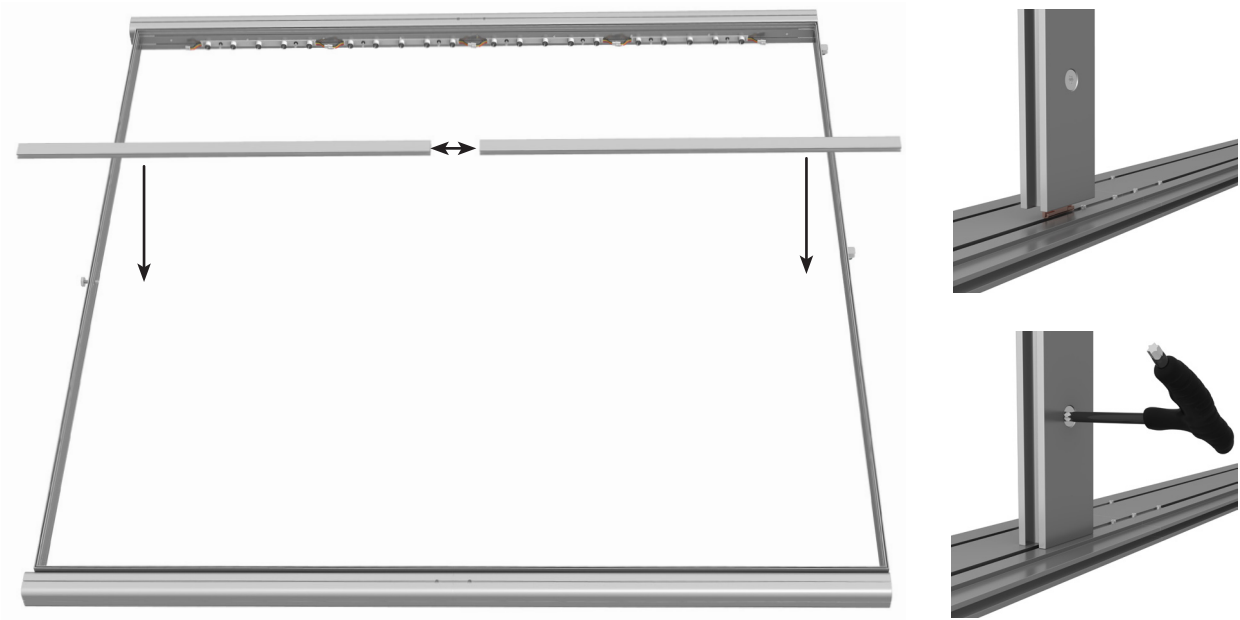

9

Attach the front panel fabric image (E) to the assembled frame. Using the silicone edge, firmly attach the fabric to all four corners of the frame. Finish by inserting the remaining edges into the creases in the frame. Repeat the process for the back graphic (F).

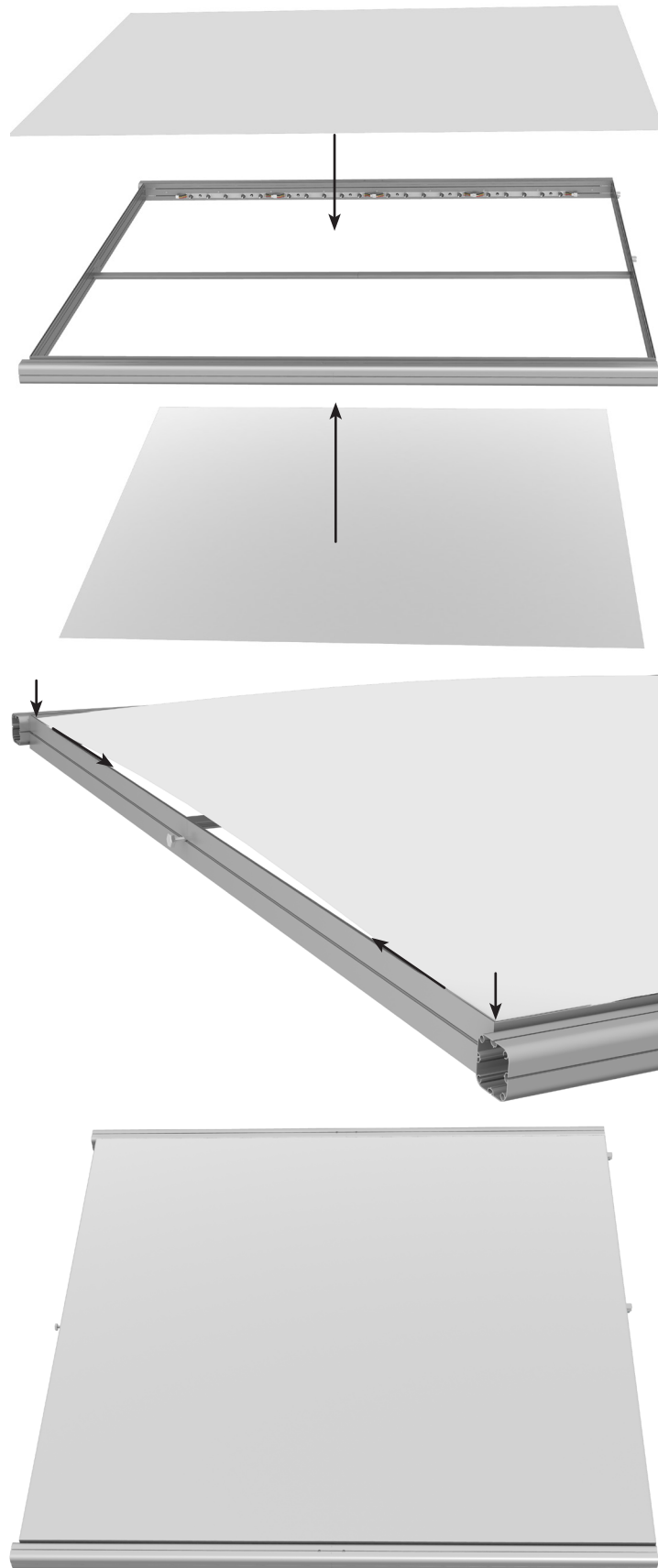

90° view after fabric is installed

- 10** Attach the feet (G) and secure using the 4 screws (H) and holes from the bottom of the foot.

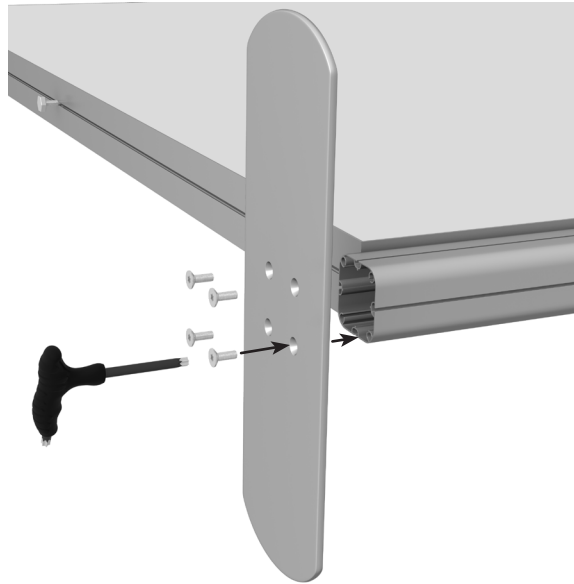

- 11** after positioning the header supports to the correct position (should match what is shown below, and on step 18), carefully place the header into both tightly secured header supports. Fasten the header in place by rotating the dials located at the rear of the header supports.
DO NOT OVER-TIGHTEN DIALS, IT COULD CAUSE DAMAGE TO THE HEADER.

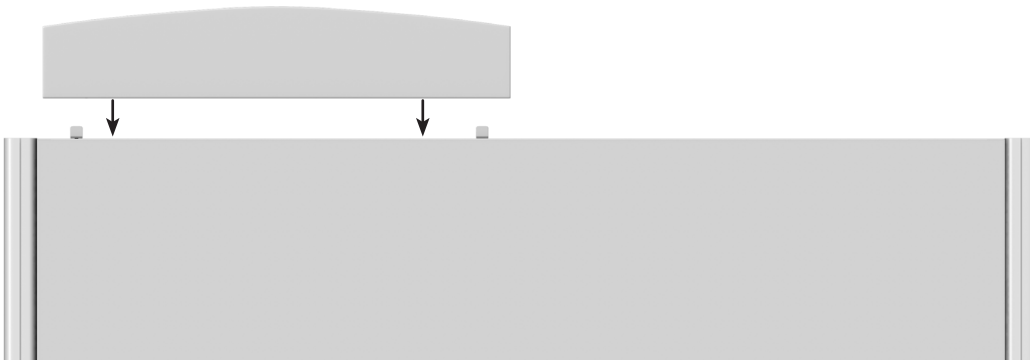

- 12** Double-check to make sure all connections are securely attached, and (**two people minimum recommended**) carefully prop up the display to its upright position.

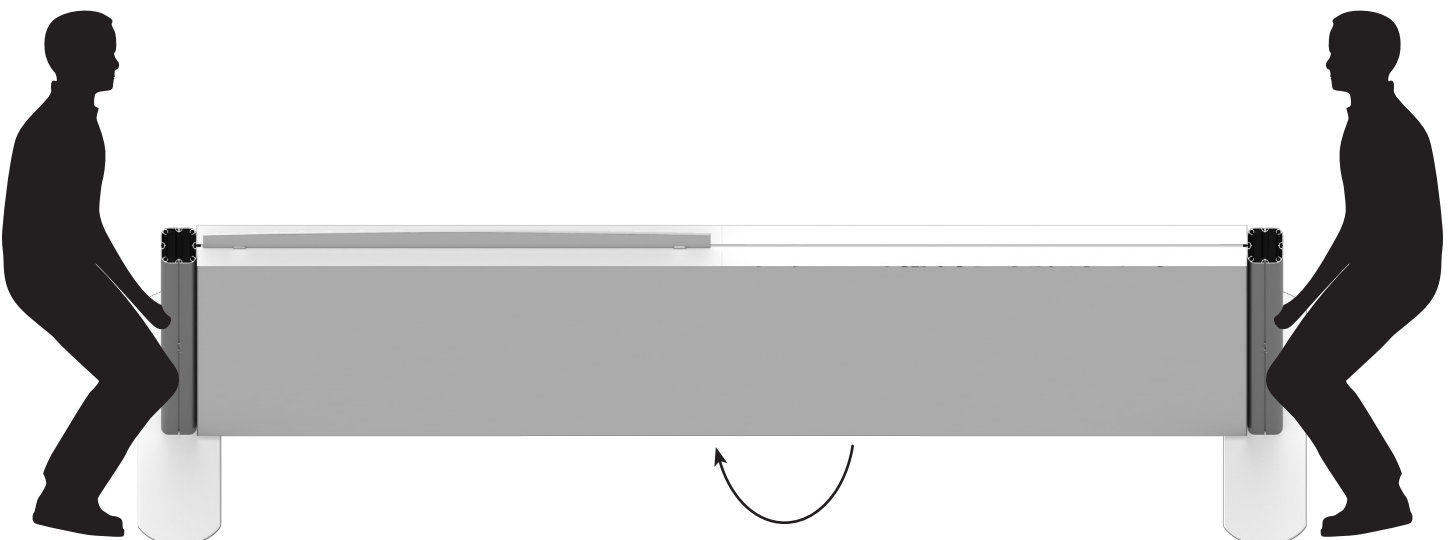

- 13** Assemble the wave-top (J,K,L) by following the diagram below.

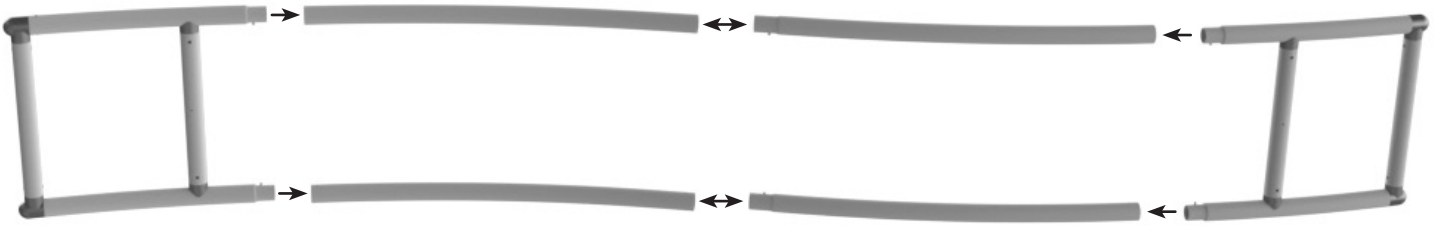

- 14** Slide the fabric cover (M) onto the wave-top, and line up the holes in the fabric over the holes in the wave-top frame.

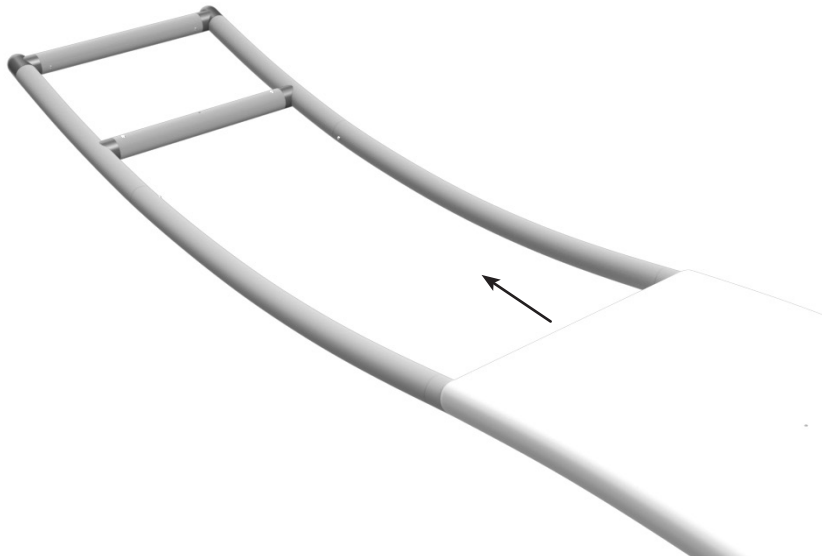

- 15** Insert the wave top bolts (N) into the openings on the top portion of the wave tube until the end of the bolt protrudes from the bottom. Place the vertical wave-top bar (O) securely against the protruding bolt, and loosely tighten just the beginning of the bolt to the bar using the tool. Repeat for the other side. Screw both sides tight.



- 16** Using two people, line-up the wave-top with the adjacent openings on both ends of the frame, and simultaneously lower into the frame until it is securely attached.

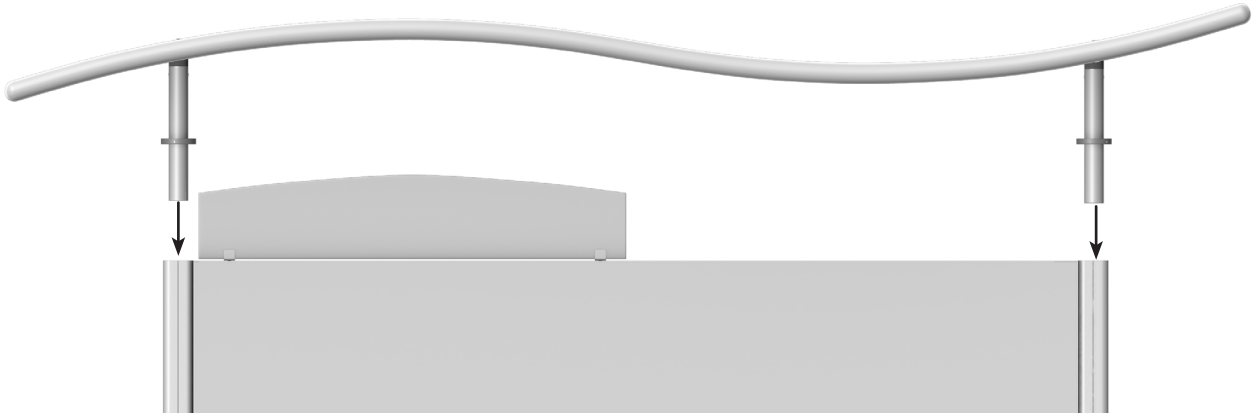

- 17** Locate the 2 fabric wing panel sections and 4 corresponding left top/right top/left bottom/right bottom wing connector pieces. Slide the top and bottom fabric edges of both panels into the creases into both top and bottom sections of the wing connector panels, until they appear like the diagram seen below.



- 18** Attach the 2 wing sections (P) of the frame using the supplied tool (each side has a top and bottom, so you will attach 4 total pieces). Insert the inside edges of fabric into the creases on the outside of the frame, until entire wing section is secure – top, bottom and inside edge.

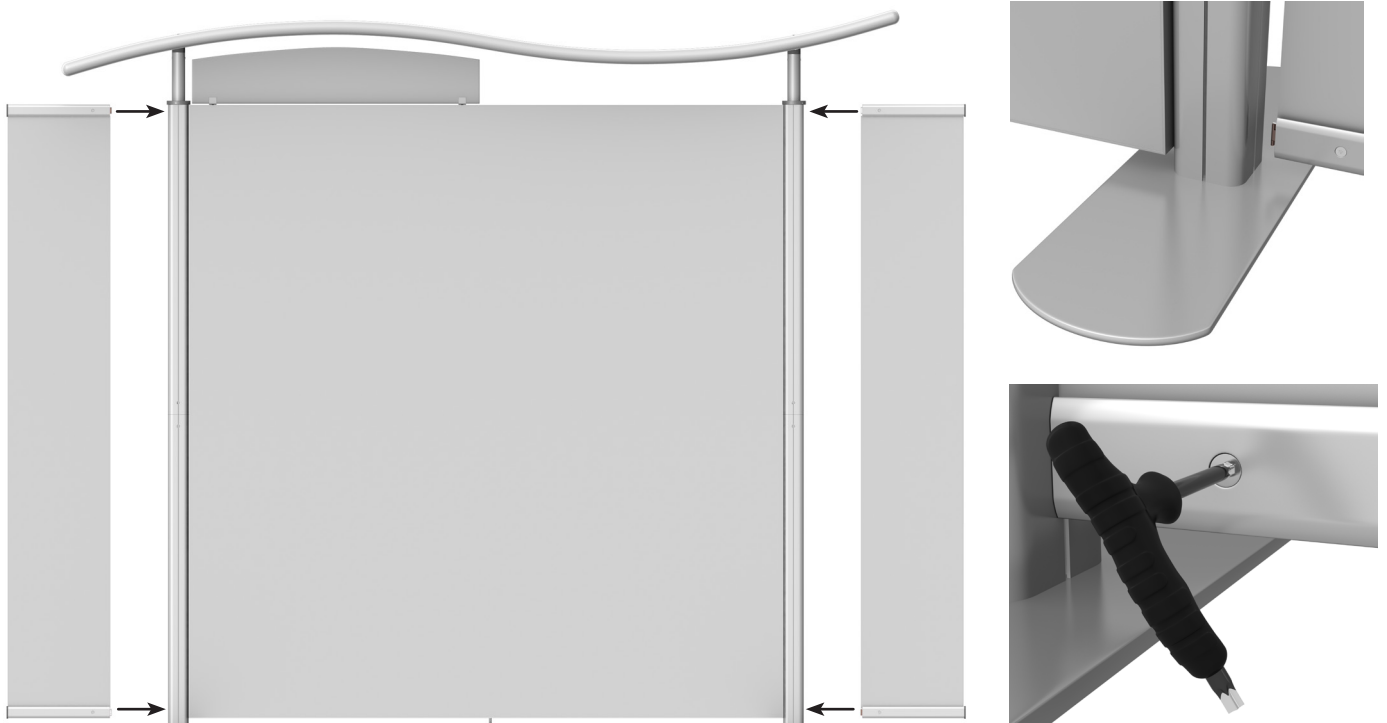

- 19** Use the support/leveling screws (Q) as needed (Ideally, they should not be needed unless the frame shows a slight bow or you are on an uneven floor).

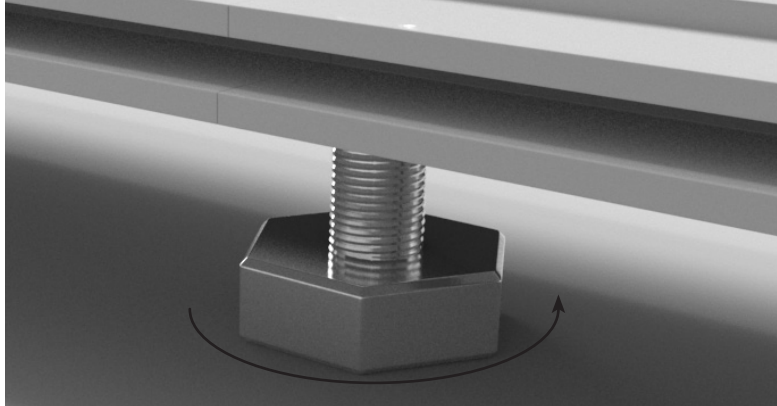

- 20** Attach power cords and plug the power into an approved electrical socket. The lights should immediately power on.

